

02 - 05.3

10.05.GB

**Control valves
G 47 ...**



Kv coefficient calculation

Calculation itself is carried out with respect to conditions of regulating circuit and operating medium according to equations mentioned below. Control valve must be designed to be able to regulate maximal flow quantity at given operating conditions. At the same time it is necessary to check whether minimal flow quantity can be even regulated or not.

Because of eventual minus tolerance 10% of Kv_{100} against Kvs and requirement for possible regulation within range of maximal flow (decrement and increase of flow), producer recommends to select Kvs value higher than maximal operating Kv value:

$$Kvs = 1.2 \div 1.3 Kv$$

It is necessary to take into account to which extent Q_{max} involve "precautionary additions" that could result in valve oversizing.

Relations of Kv calculation

		Pressure drop $p_2 > p_1/2$ $\Delta p < p_1/2$	Pressure drop $\Delta p \geq p_1/2$ $p_2 \leq p_1/2$
Kv =	Liquid	$\frac{Q}{100} \sqrt{\frac{\rho_1}{\Delta p}}$	
	Gas	$\frac{Q_n}{5141} \sqrt{\frac{\rho_n \cdot T_1}{\Delta p \cdot p_2}}$	$\frac{2 \cdot Q_n}{5141 \cdot p_1} \sqrt{\rho_n \cdot T_1}$
	Superh. steam	$\frac{Q_m}{100} \sqrt{\frac{v_2}{\Delta p}}$	$\frac{Q_m}{100} \sqrt{\frac{2v}{p_1}}$
	Sat. steam	$\frac{Q_m}{100} \sqrt{\frac{v_2 \cdot x}{\Delta p}}$	$\frac{Q_m}{100} \sqrt{\frac{2v \cdot x}{p_1}}$

Above critical flow of vapours and gases

When pressure ratio is above critical ($p_2/p_1 < 0.54$), speed of flow reaches acoustic velocity at the narrowest section. This event can cause higher level of noisiness and then it is convenient to use a throttling system ensuring low noisiness (multi-step pressure reduction, damping orifice plate at outlet).

Dimensions and units

Marking	Unit	Name of dimension
Kv	m ³ /hour	Flow coefficient under conditions of units of flow
Kv_{100}	m ³ /hour	Flow coefficient at nominal stroke
Kvs	m ³ /hour	Valve nominal flow coefficient
Q	m ³ /hour	Flow rate in operating conditions (T_1, p_1)
Q_n	Nm ³ /hour	Flow rate in normal conditions (0 °C, 0.101 MPa)
Q_m	kg/hour	Flow rate in operating conditions (T_1, p_1)
p_1	MPa	Upstream absolute pressure
p_2	MPa	Downstream absolute pressure
p_s	MPa	Absolute pressure of saturated steam at given temperature (T_1)
Δp	MPa	Valve differential pressure ($\Delta p = p_1 - p_2$)
ρ_1	kg/m ³	Process medium density in operating conditions (T_1, p_1)
ρ_n	kg/Nm ³	Gas density in normal conditions (0 °C, 0.101 MPa)
v_2	m ³ /kg	Specific volume of steam when temperature T_1 and pressure p_2
v	m ³ /kg	Specific volume of steam when temperature T_1 and pressure $p_1/2$
T_1	K	Absolute temperature at valve inlet ($T_1 = 273 + t_1$)
x	1	Proportionate weight volume of saturated steam in wet steam

Cavitation

Cavitation is a phenomenon when there are steam bubbles creating and vanishing in shocks - generally at the narrowest section of flowing due to local pressure drop. This event expressively cuts down service life of inner parts and can result in creation of unpleasant vibrations and noisiness. In control valves it can happen on condition that

$$(p_1 - p_2) \geq 0.6 (p_1 - p_s)$$

Valve differential pressure should be set the way so that neither any undesired pressure drop causing cavitation can occur, nor liquid-steam(wet steam) mixture can create. Otherwise it must be taken into account when calculating Kv value. If the creation of cavitation still threatens, it is necessary to use a multi-step pressure reduction.

Valve flow characteristics

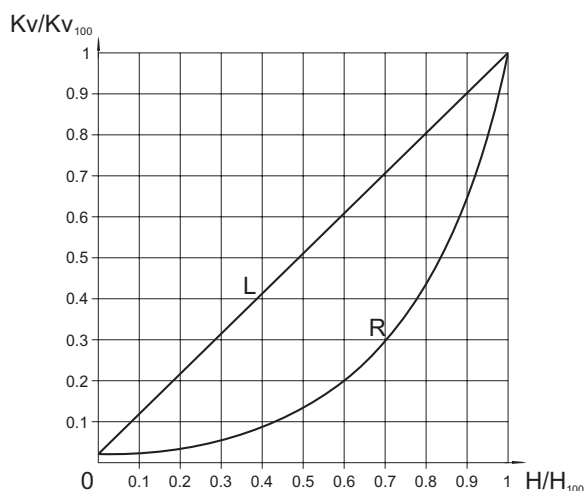

L - linear characteristic

$$Kv/Kv_{100} = 0.0183 + 0.9817 \cdot (H/H_{100})$$

R - equal-percentage characteristic (4-percentage)

$$Kv/Kv_{100} = 0.0183 \cdot E^{(4 \cdot H/H_{100})}$$

Diagram for the valve Kvs value specification according to the required flow rate of water Q and the valve differential pressure Δp

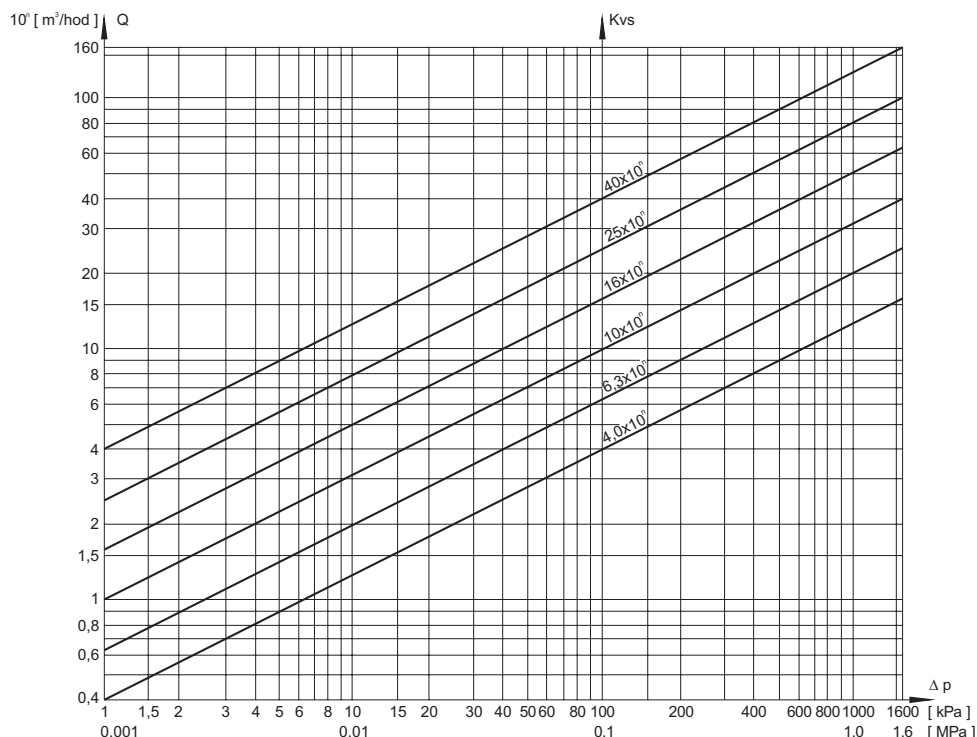

The diagram serves to specify the valve Kvs value regarding to the required flow rate of water at a given differential pressure. It can be also used for finding out the differential pressure value of the existing valve in behaviour with the flow rate. The diagram applies to water with the density of 1000 kg/m³.

For the value $Q = q \cdot 10^3$, it is necessary to calculate with $Kvs = k \cdot 10^3$. Example: water flow rate of $16 \cdot 10^3 = 1,6 \text{ m}^3/\text{hour}$ corresponds to $Kv = 2,5 = 25 \cdot 10^3$ when differential pressure 40kPa.

Valve complete specification No. for ordering G 47

		X XX	X X X	- X XXX	/ XXX	- XXX
1. Valve	Control valve	G				
2. Series	Lever control valves, double-seated	47				
3. Flow direction	Straight - through		1			
4. Connection	Flanged		1			
	Weld ends		2			
5. Actuating	Adjusted for remote control		5			
6. Material	Alloy steel 1.7357			2		
	Carbon steel 1.0619			5		
7. Nominal pressure PN	Acc. to the valve execution			XXX		
8. Max. operating temp. °C	Acc. to the valve execution				XXX	
9. Nominal size DN	Acc. to the valve execution					XXX

Maximal permissible pressures acc. to EN 12 516-1 [MPa]

Material	PN	Temperature [°C]							
		200	250	300	350	400	450	500	550
Cast steel 1.0619	125	8.9	8.1	7.3	6.8	6.6	---	---	---
	160	11.4	10.4	9.4	8.8	8.4	---	---	---
	250	17.8	16.2	14.7	13,7	13,2	---	---	---
Alloy steel 1.7357	160	14.9	14.3	13.3	12,3	11.5	10.7	8.9	3.5
	250	23.3	22.3	20.8	19.3	18	16.7	13.9	5.5
	320	29.8	28.6	26.6	24.6	23.0	21.4	17.8	7.0
	500	46.6	44.6	41.6	38.6	36.0	33.4	27.8	11.0



Lever control valves DN 150, 200, 250 PN 250

Description

The valve is piston type equipped with control cage, lever-actuated designed to be actuated with an electric actuator. Its control cage is always designed according to the parameters specified in the order and according to the requested type of flow characteristic.

The valves can be supplied with the following actuators of the following producer: ZPA Pečky - Modact MPS, Modact Control MPS and Modact Variant MPR. The control of the actuators is 3-position or continuous with signal of 4-20 mA or 0-10 V. The connection stem between the valve lever and the actuator is not a subject of the delivery unless it is ordered.

Application

The valve serves as a control, reduction or by-pass element with indirect actuating. The max. permissible operating pressures acc. to EN 12 516-1 see page 3 of this catalogue. The intention to use the valve for higher temperatures must be agreed upon with the producer. The control valve proper function depends on the sizing and execution of the control station, therefore the valve design and its specification is recommended to be carried out together with the producer.

Process media

The valves are designed to regulate the flow and pressure of liquids, possibly of vapours and gases e.g. water, steam and other media compatible with material of the valve inner parts. The valve max. differential pressure value is 1,5 MPa with respect to the pressure nominal and concrete conditions of operation (ratio p_1/p_2 , creation of cavitation, above critical flow etc.)

Installation

The valve can be piped in a horizontal pipeline with vertically positioned stem and the valve lever up positioned above the valve body. The medium flow direction shall coincide with the arrows indicated on the valve body. The lever is mounted on the right side from the medium flow direction unless it is required otherwise.

Technical data

Series	G 47 115 5250
Type of valve	Control valves (feeding), flanges, straight-through
Nominal size	150, 200, 250
Nominal pressure	250
Body material	Carbon steel 1.0619
Process media temp. range	-20 to 400°C
Connection *	ČSN 13 1217
Type of trim	Cage - double-piston plug
Flow characteristic	Linear, equal-percentage acc. to ČSN EN 60 534-1 (4/1997)
Flow area range F_s [cm ²]	5 - 112
Kvs value range	15 - 336
Leakage rate	Class II acc. to ČSN EN 1349 (5/2001)

*) mentioned ČSN are from 1963. After the agreement with the producer, it is possible to make the connection acc. to ČSN 13 1060 (7/1995) or ČSN EN 1092-1 (4/2002).

Dimensions and weights for G 47 115

Type	G 47 115 5250			
DN	[mm]	150	200	250
L	[mm]	750	950	950
L ₁	[mm]	480 840	480 840	530 636
L ₂	[mm]	120	120	106
~V	[mm]	700	700	718
~V ₁	[mm]	210	252	250
D	[mm]	115	163	201
D ₁	[mm]	390	485	585
D ₂	[mm]	320	400	490
D ₆	[mm]	240	305	375
A	[mm]	152 266	152 266	240 288
f	[mm]	3	3	3
a	[mm]	70	85	100
d	[mm]	36	42	48
n	[mm]	12	12	16
Stroke	[mm]	38	38	48
Fs	[cm ²]	5-92	5-92	10-112
Kvs	[m ³ /h]	15-276	15-276	30-336
m	[kg]	420	625	870

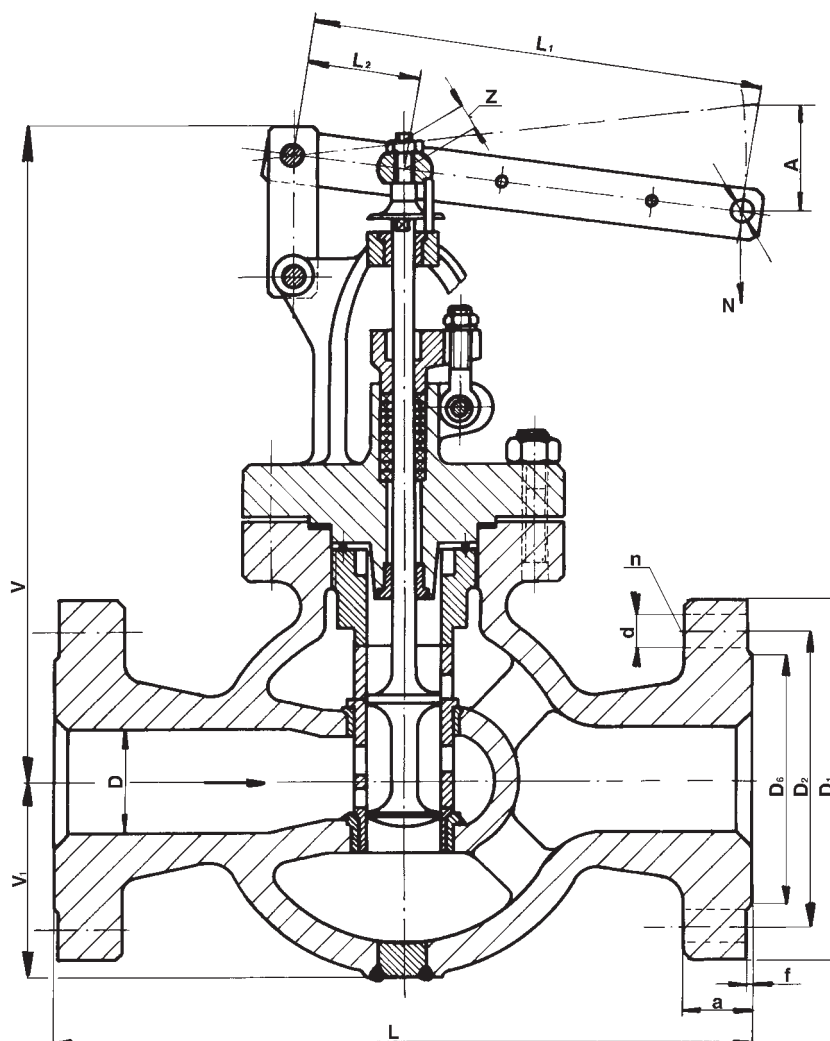



Lever control valves DN 125 to 300, PN 125 to 500

Description

The valve is piston type equipped with control cage, lever-actuated designed to be actuated with an electric actuator. They can be actuated even with linear or rotative actuator. Its control cage is always designed according to the parameters specified in the order and according to the requested type of flow characteristic.

The valves can be supplied with the following actuators of the following producers: ZPA Pečky - Modact MPS, Modact Control MPS and Modact Variant MPR and ZPA Křižík Prešov - Modact Variant MTR, possibly with linear actuators ZPA Pečky, Regada Prešov and rotative actuators Auma or Schiebel. The connection stem between the valve lever and the actuator is not a subject of the delivery unless it is ordered.

Application

The valve serves as a control, reduction or by-pass element with indirect operating. The max. permissible operating pressures acc. to EN 12 516-1 see page 3 of this catalogue. The intention to use the valve for higher temperatures must be agreed upon with the producer. The control valve proper function depends on the sizing and execution of the control station, therefore the valve design and its specification is recommended to be carried out together with the producer.

Process media

The valves are designed to regulate the flow and pressure of feeding pressure to a steam boiler. The valve max. differential pressure value is 1,5 MPa with respect to the pressure nominal and concrete conditions of operation (ratio p_1 / p_2 , creation of cavitation, above critical flow etc.)

Installation

The valve may be piped only in a horizontal pipeline with vertically positioned stem and lever positioned above the valve body. The medium flow direction shall coincide with the arrows indicated on the valve body.

Technical data

Series	G 47 125 2160	G 47 125 2250	G 47 125 2320	G 47 125 2500	G 47 125 5125	G 47 125 5160	G 47 125 5250
Type of valve	Control valves (feeding), weld ends, straight-through						
Nominal size range	200	125	150, 200, 250, 300	300	150	200	150, 200 250
Nominal pressure	160	250	320	500	125	160	250
Body material	Alloy steel 1.7357				Carbon steel 1.0619		
Process media temp. range	-20 to 575°C				-20 to 400°C		
Connection *	ČSN 13 1070						
Type of trim	Cage - double-piston plug						
Flow characteristic	Linear, equal-percentage acc. to ČSN EN 60 534-1 (4/1997)						
Flow area range F_s [cm ²]	10 - 92	3,6 - 48	10 - 145	40 - 145	3,5 - 92	3,5 - 92	5 - 112
Kvs value range	30 - 276	10,8 - 144	30 - 435	120 - 435	10,5 - 276	10,5 - 276	15 - 336
Leakage rate	Class II acc. to ČSN EN 1349 (5/2001)						

*) After the agreement with the producer, it is possible to make the connection acc. to the valid ČSN 13 1075 (3/1991) or ČSN EN 12 627 (8/2000)

Dimensions and weights for G 47 125

Type		G 47 125 2160	G 47 125 2250	G 47 125 2320				G 47 125 2500	G 47 125 5125	G 47 125 5160	G 47 125 5250		
DN	[mm]	200	125	150	200	250	300	300	150	200	150	200	250
D	[mm]	219	133	159	219	273	324	324	159	219	159	219	273
L	[mm]	900	800	1120	900	1050	1050	1050	976	1120	976	1120	1050
L ₁	[mm]	530	530	530	530	500	500	1125	480	480	480	480	530
L ₂	[mm]	106	106	106	106	125	125	125	120	120	120	120	106
~V	[mm]	800	668	700	800	782	782	782	700	700	700	700	720
~V ₁	[mm]	250	175	250	250	275	275	275	250	250	250	250	250
A	[mm]	240	155	240	240	248	248	558	152	152	152	152	240
t	[mm]	20	18	28	25	36	32	32	10	28	22	28	36
Stroke	[mm]	48	31	48	48	62	62	62	38	38	38	38	48
Fs	[cm ²]	10-92	3,6-48	10-92	10-92	40-145	40-145	40-145	3,5-92	3,5-92	3,5-92	3,5-92	10-112
Kvs	[m ³ /h]	30-276	10,8-144	30-276	30-276	120-435	120-435	120-435	10,5-276	10,5-276	10,5-276	10,5-276	30-336
m	[kg]	630	400	471	650	890	950	980	441	625	451	517	916

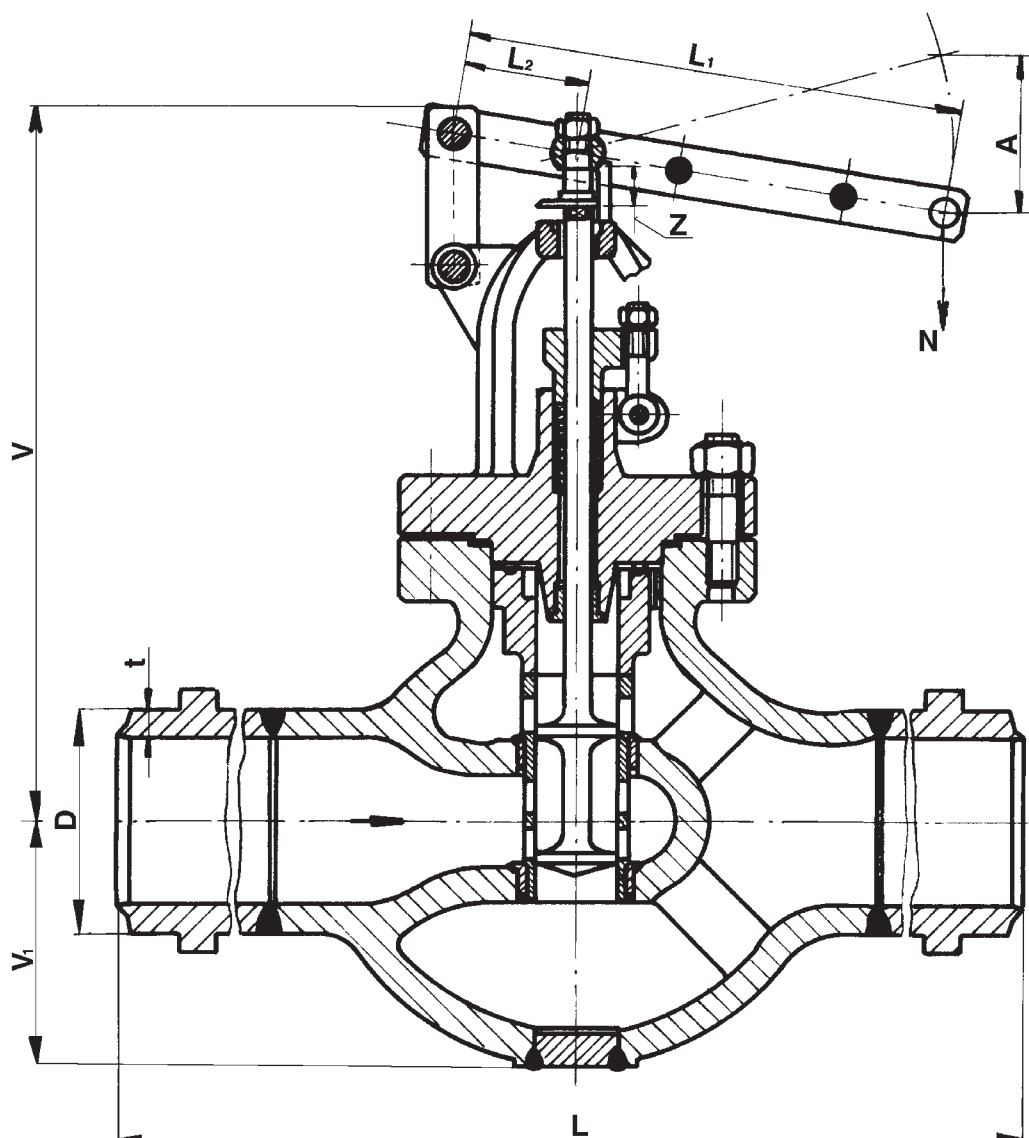

52 262
52 263
52 264

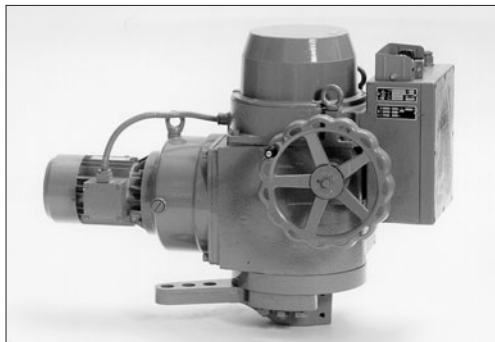

Electric actuators Modact MPS and Modact MPS Control ZPA Pečky

Technical data

Type	Modact MPS	Modact MPS Control
Voltage	3 x 230 V / 400 V ± 6%	
Frequency	50 Hz	
Motor power	See specification table	
Control	2 - position or 3 - position control	
Torque range	160 to 1250 Nm	
Travel range	60° to 160°	
Enclosure	IP 55	
Process media max. temperature	Acc. to used valve	
Ambient temperature range	-25 to 55°C	
Ambient humidity range	10 - 100 % with condensation	
Weight	max. 120 kg	

Wiring diagram of actuator Modact MPS

Execution - terminal board

Position transmitter : resistance 2x100 Ω

Position transmitter : capacity CPT 1 1/A 4 - 20 mA

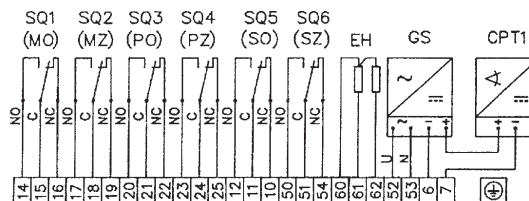
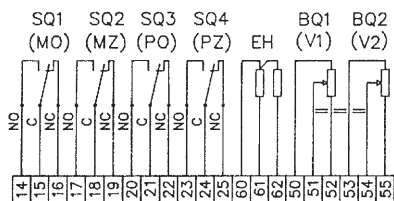

Wiring diagram of actuator Modact MPS Control

With current transmitter, built-in contactor combination, heat relay, positioner ZP2.RE and dynamic brake BAM-001.

- SQ1 (MO) torque switch in "opening" direction
- SQ2 (MZ) torque switch in "closing" direction
- SQ3 (PO) limit switch in "opening" direction
- SQ5 (PZ) limit switch in "closing" direction
- SQ4 (SO) signalisation switch in "opening" direction
- SQ6 (SZ) signalisation switch in "closing" direction
- EH heaters 2 x TR 551 10k/A
- CPT1 capacity position transmitter CPT1/A 4 - 20 mA
- BAM-001 dynamic brake
- KO contactor in "opening" direction
- KZ contactor in "closing" direction
- F heat relay
- SA1 control switch "local-remote"
- SA2 switch "open - close"
- BQ1, BQ2 position transmitter 2 x 100 Ω
- ZP2.RE micro-computer positioner
- GS power supply source for current transmitter 230V/24V
- M1~ one-phase motor
- M3~ inductive, three-phase motor
- C motor capacitor
- T mains transformer
- S terminal board
- Z plug "KBNS"

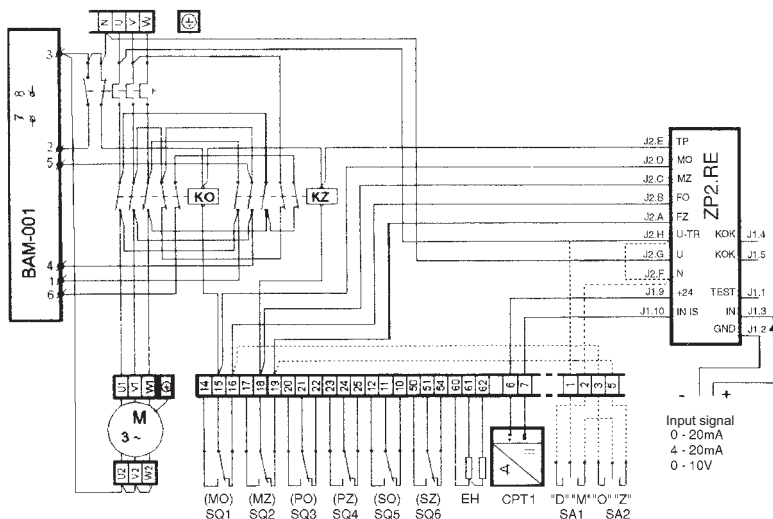

Specification for actuators Modact MPS and Modact MPS Control

Basic equipment : 1 electromotor 2 heaters
 2 torque switches MO, MZ 2 signalisation switches SO, SZ - for actuators with CPT 1/A
 2 limit switches PO, PZ and actuators without any transmitter

Basic technical data :

Type	Tripping torque setting range [Nm]	Running time [s/90°]	Electromotor			Oil filling [l]	Weight [kg]	Specification No..	
			Motor power [W]	Current to motor In [A]	Current to motor Iz [A]			Basic	Additional
MPS 32/16	160 - 320	16	180	0,57	1,82	3,4	70	52 262	XX1X
MPS 32/32		32							XX2X
MPS 32/63		63							XX3X
MPS 32/120		120							XX4X
MPS 63/16	320 - 630	16	370	1,05	3,25	10	120	52 263	XX1X
MPS 63/32		32							XX2X
MPS 63/63		63							XX3X
MPS 63/120		120							XX4X
MPS 125/16	630 - 1250	16	370	1,05	3,25	10	120	52 264	XX1X
MPS 125/32		32							XX2X
MPS 125/63		63							XX3X
MPS 125/120		120							XX4X

Execution, electric connection :

Via terminal board 6XXX
 With connector KBSN (for Modact MPS only) 7XXX

Operating travel -mechanically connected with controlled element	with lever and flange with stops	60°	X1XX
		90°	X2XX
		120°	X3XX
		160°	X4XX

Additional equipment for actuators Modact MPS	Resistance position transmitter 2 x 100 Ω	XXX1
	Execution without any position transmitter	XXX0
	Current pos. transmitter CPT 1/A 4-20 mA with built-in power supply generator	XXX7
	Current pos. transmitter CPT 1/A 4-20 mA wo. built-in power supply generator	XXX9

Additional equipment for actuators Modact MPS Control	Completely equipped with positioner and brake BAM		Without positioner, with brake BAM and reversible contactors		Without positioner and brake BAM, with reversible contactors	
	with BMO	without BMO	with BMO	without BMO	with BMO	without BMO
Without position transmitter	---	---	XXXC	XXXL	XXXG	XXXR
Resistance position transmitter 2 x 100 Ω	---	---	XXXD	XXXM	XXXH	XXXS
CPT 1/A 4-20 mA with built-in power supply generator	---	---	XXXE	XXXN	XXXJ	XXXT
CPT 1/A 4-20 mA without built-in power supply generator	XXXA	XXXB	XXXF	XXXP	XXXK	XXXU

Dimensions of actuator Modact MPS and Modact MPS Control

	52 262	52 263	52 264
A	620	712	731
B	386	460	479
C	234	252	
D	200	250	
E	62	82	
E ₁	60	80	
F	346	420	
G	340	445	
G ₁	456	562	
J	120	145	
K	70	100	
L	90	110	
M	140	200	
N	41	60	
O	14	18	
S	56	70	
T	4	7	
U	25	30	
X	65	80	
Y	41	55	
Z	273	278	
d	40 h 8	50 h 8	
d ₁	40 H 7	50 H 7	
d ₂	3x 20H8	3x 25H8	
b	12 P9	16 P9	
h	8	10	
e	35	43,8	

Modact MPS

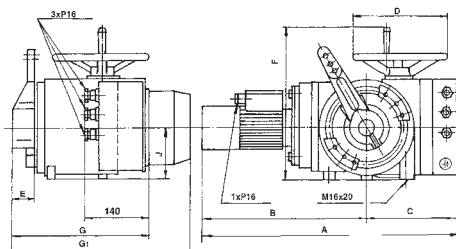

Modact MPS Control

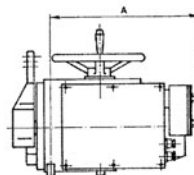

	52 262	52 263	52 264
A	370	440	
B	250	275	

Lever

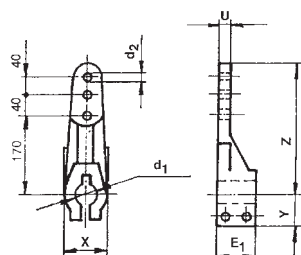

Base board - holes

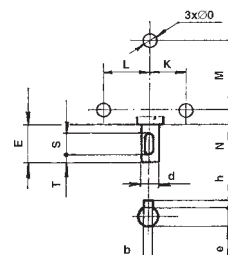

52 222
52 223



Electric actuators
Modact Variant MPR
ZPA Pečky

Technical data

Type	Modact Variant MPR
Voltage	230 V ± 6%
Frequency	50 Hz
Motor power	50 W
Control	Continuous
Torgue range	250 to 4000 Nm
Travel range	60° to 160°
Enclosure	IP 55
Process media max. temperature	Acc. to used valve
Ambient temperature range	-25 to 55 °C
Ambient humidity range	10 - 100 % with condensation
Weight	max. 282 kg

Wiring diagram of actuator

Execution - terminal board
With resistance transmitter 2x100 Ω

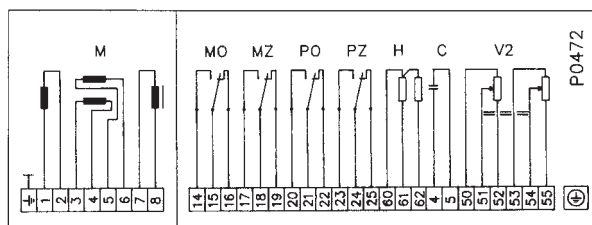

- MO torque switch in "opening" direction
- MZ torque switch for "closing" direction
- PO limit switch in "opening" direction
- PZ limit switch in "closing" direction
- SO signalisation switch in "opening" direction
- SZ signalisation switch in "closing" direction
- H heaters
- CPT1 capacity position transmitter
CPT1/A 4 - 20 mA
- V2 resistance position transmitter 2 x 100 Ω
- GS power supply source for current transmitter 230V/24V
- M induction, two-phase motor
- C capacitor
- S terminal board
- Z plug "KBNS"

With current transmitter CPT1/A, without built-in power supply source

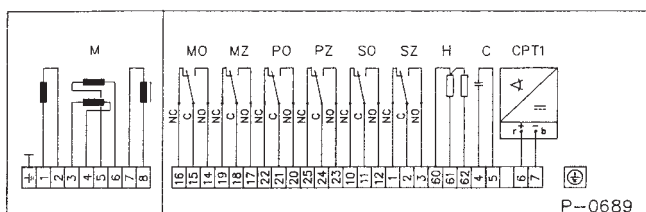

With current transmitter CPT1/A with built-in power supply source

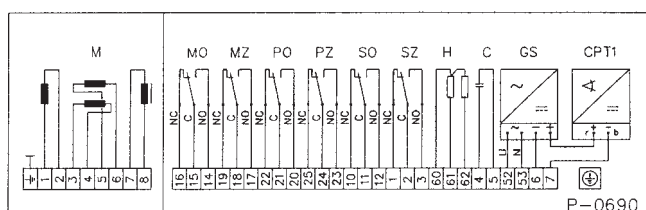

Specification of actuator Modact Variant MPR

Type	Nominal torque [Nm]	Max. torque [N/m]	Running time range [sec/90°]	Electromotor			Oil filling [kg]	Weight [kg]	Specification No.		
				[W]	[μF]	BF/Rf [A]			Basic	Additional	
MPR 25-40	250-400	1400	10-19	50	8	0,6/0,6	4,4	104	52 222	XX0X	
MPR 40-63	400-630	1750	14-30							XX1X	
MPR 63-100	630-1000	2650	30-55							XX2X	
MPR 100-200	1000-2000	4550	50-80	50	8	0,6/0,6	4,4	282	52 223	XX0X	
MPR 160-300	1600-3000	5950	73-138							XX1X	
MPR 250-400	2500-4000	8940	130-195							XX2X	
Execution, electrical connection :											
Via terminal board										6XXX	
With conector KBSN										7XXX	
Operating travel							60° for 52 222		67,5° for 52 223		X1XX
							90° for 52 222		90° for 52 223		X2XX
							120° for 52 222		112,5° for 52 223		X3XX
							160° for 52 222		157° for 52 223		X4XX
							90° for 52 222; direct connection.				X5XX
Additional electric equipment		Execution without position transmitter								XXX1	
		V2 Position resistance transmitter 2 x 100 Ω								XXX0	
		CPT1+GS Position current transmitter CPT 1/A 4-20 mA with built-in power supply generator								XXX7	
		CPT1 Position current transmitter CPT 1/A 4-20 mA wo. built-in power supply generator								XXX9	
Stem		with single stem For export only								XXXX/3	
		with double stem For export only								XXXX/4	

Dimensions of actuator Modact Variant MPR

	52 222	52 223
A	782	793
B	517	548
C	265	220
D	□250	□300
E	85	123
E ₁	80	120
F	420	560
G	555	750
J	145	260
K	100	185
L	110	---
M	200	200
N	57	33
O	□18	□22
P	40	55
R	170	400
S	70	180
T	7	11
U	30	36
X	80	130
Y	55	80
Z	278	490
d	□50 h 8	□90 h 8
d ₁	□40 h 7	□90 h 7
d ₂	3x.25H8	3x.40h8
b	16 P9	25 P9
h	10	14
e	43,8	81,3

Modact Variant MPR 52 222

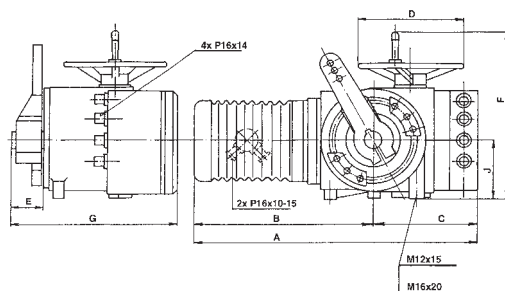

Modact Variant MPR 52 223

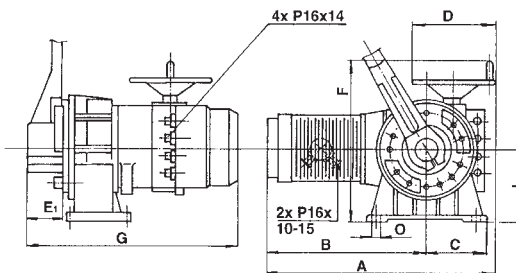

Lever

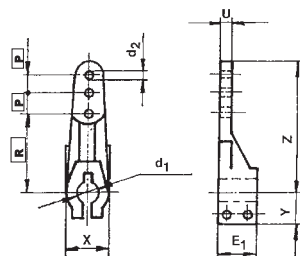

Lever

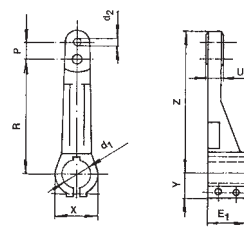

Base board - holes

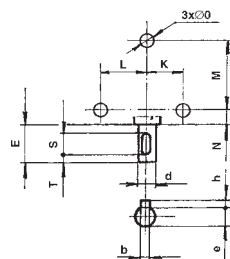

Base board - holes

